

# IP558SP Receiving Frame

## Engineering Graphic

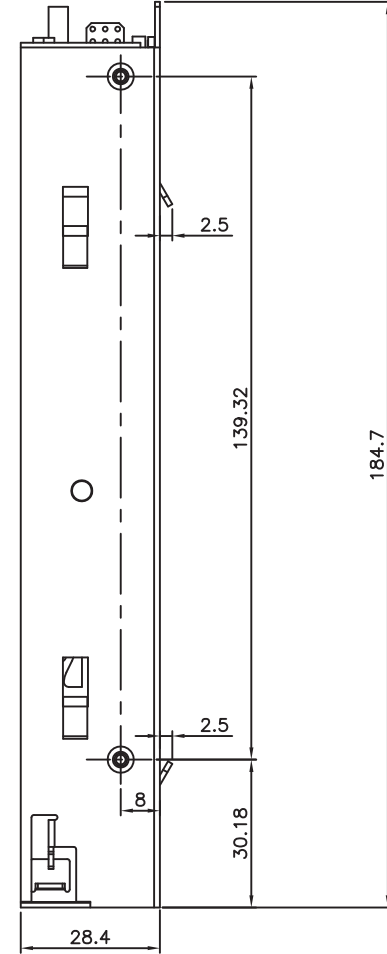
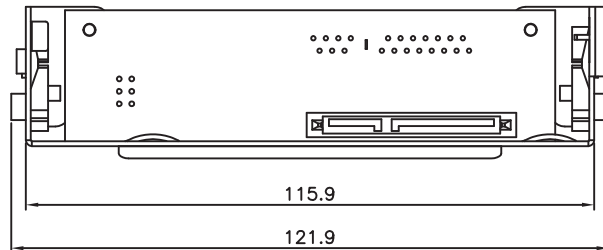
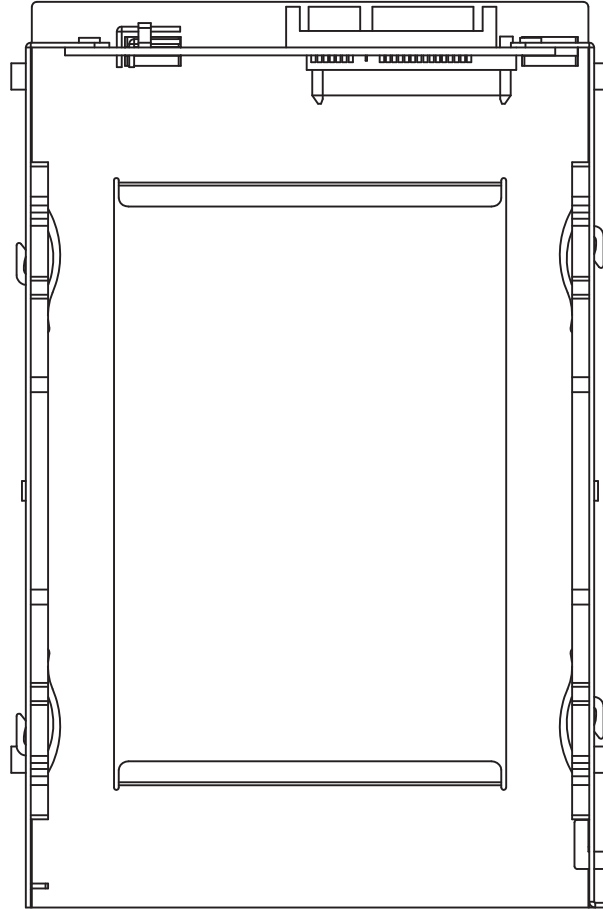
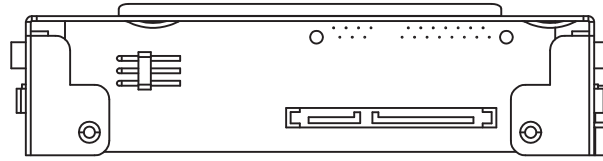
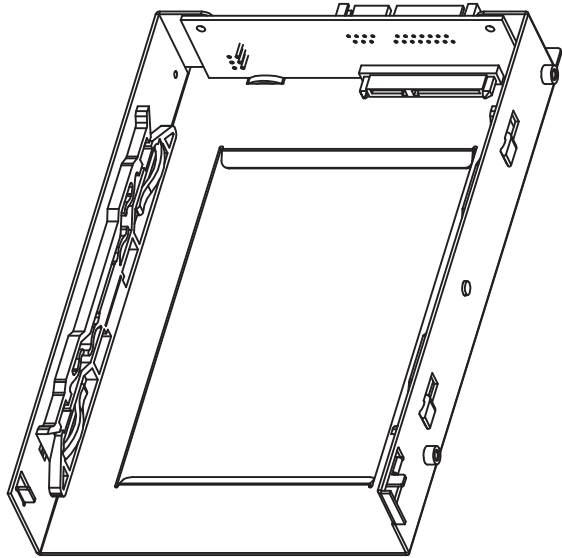

Unit: mm

# IP558SP Receiving Frame Chassis

## Engineering Graphic

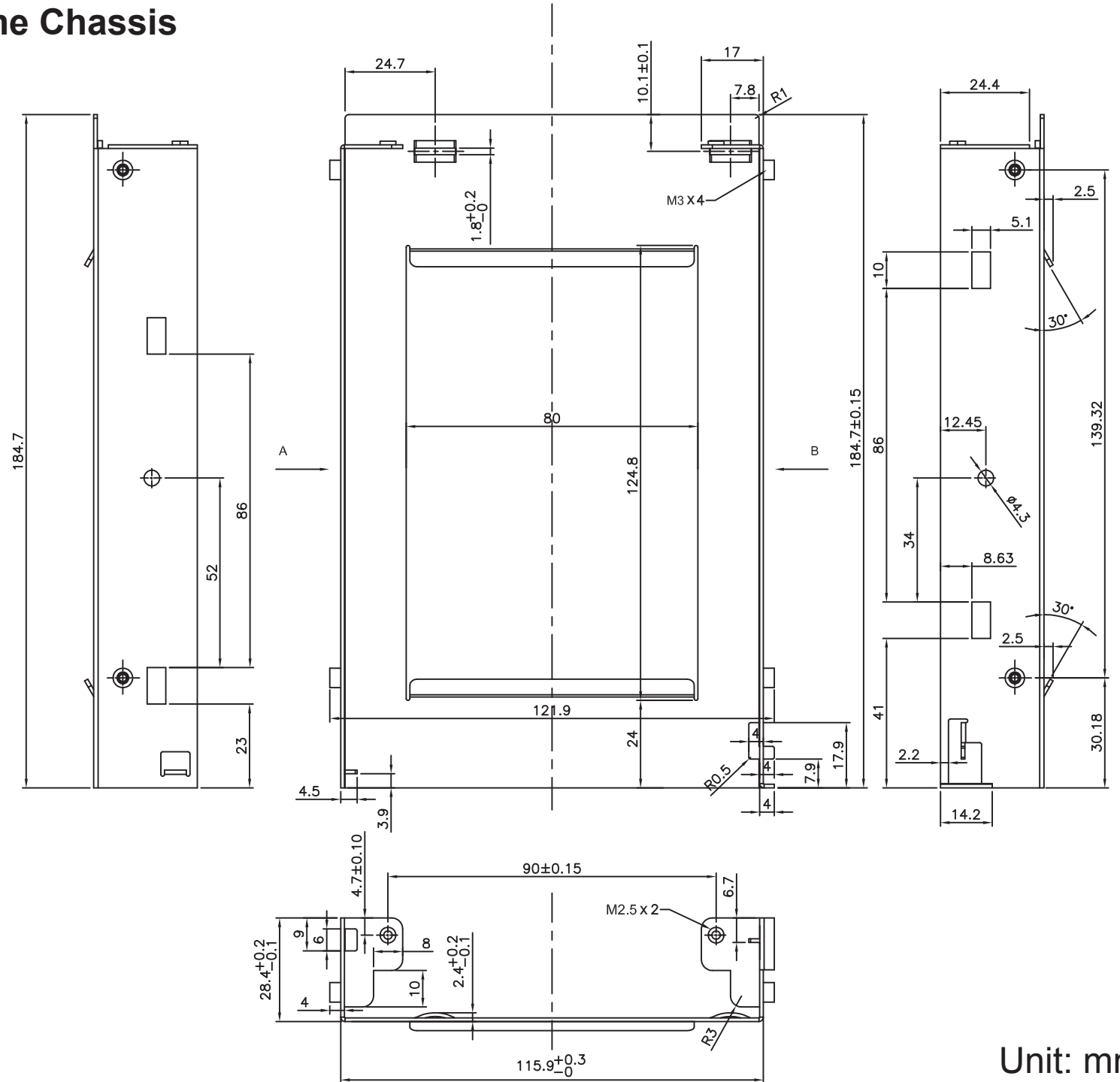
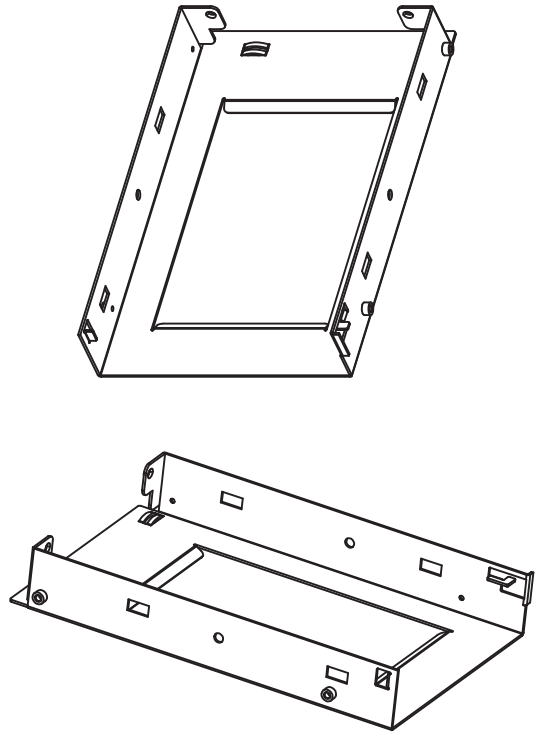

Unit: mm

# IP558SP Drive Tray

Engineering Graphic

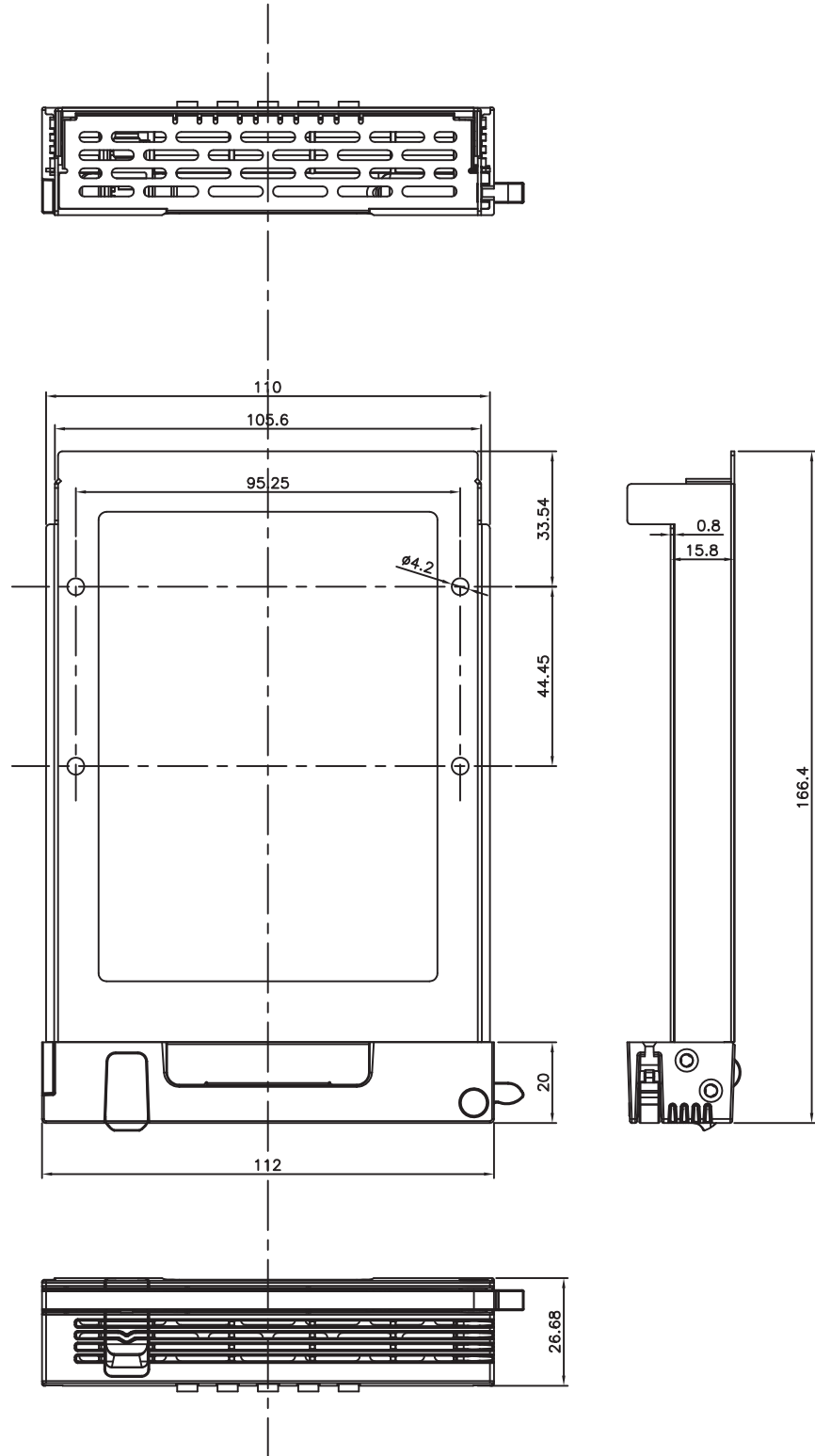
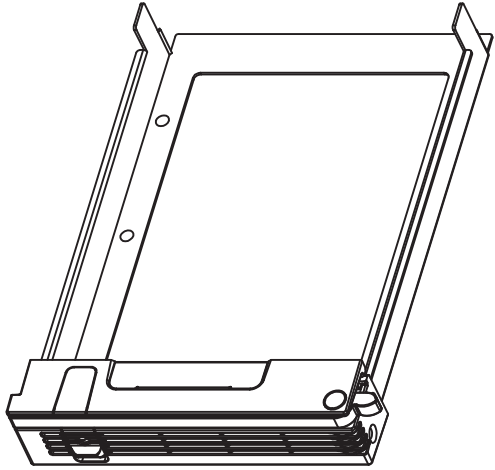

Unit: mm

# IP558SP Drive Tray Chassis

## Engineering Graphic

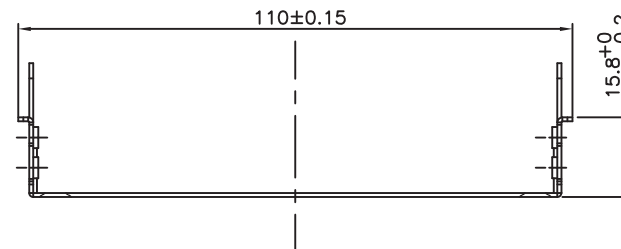
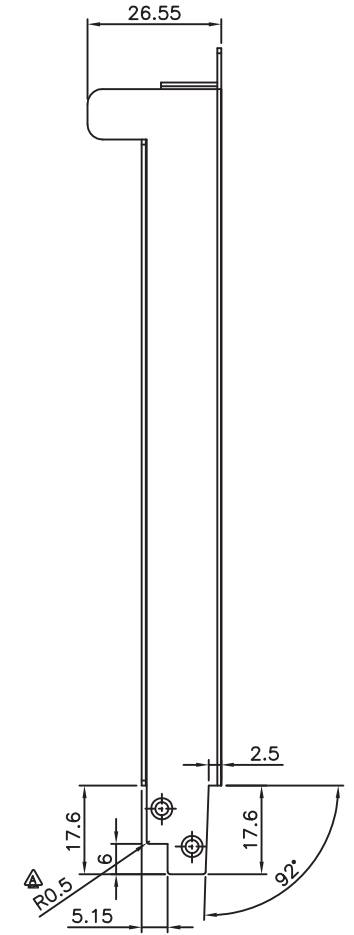
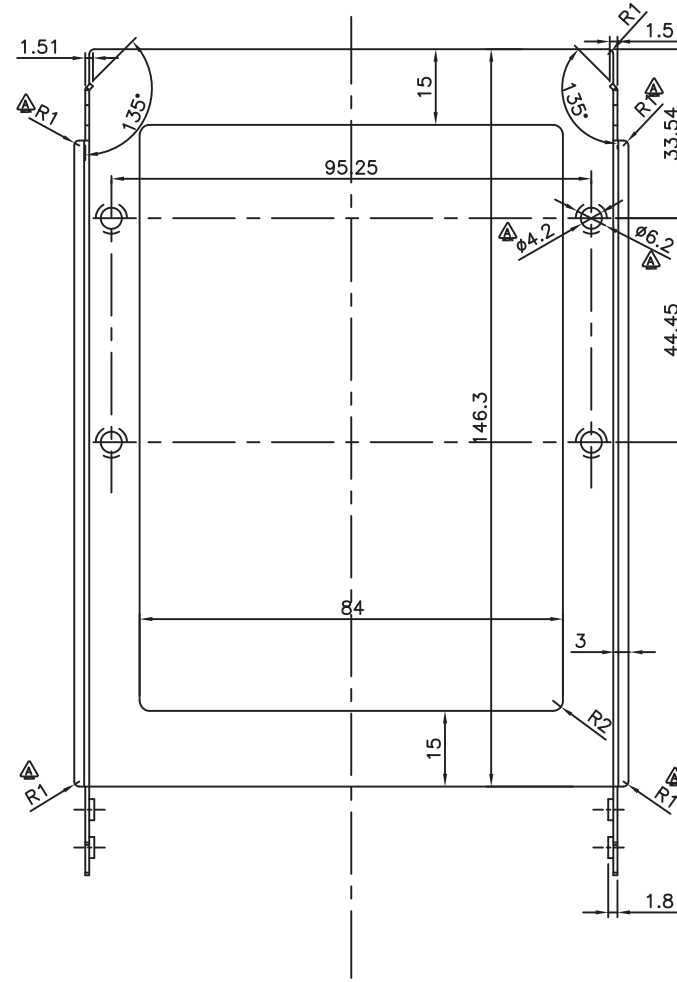
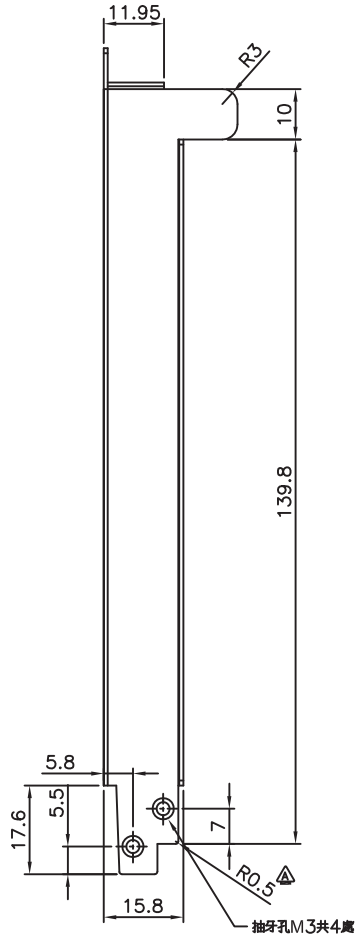
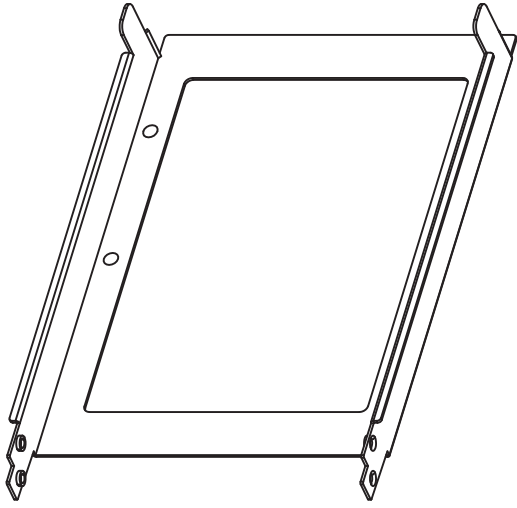

Unit: mm